

Islands

Durbanis
2019



Dimensioni cm

Materiale: Cemento armato colorato in massa, acidato e impermeabilizzato. Peso: Island S1 1.800 kg / Island L1 2.500 kg. / Island L2 3.000kg.

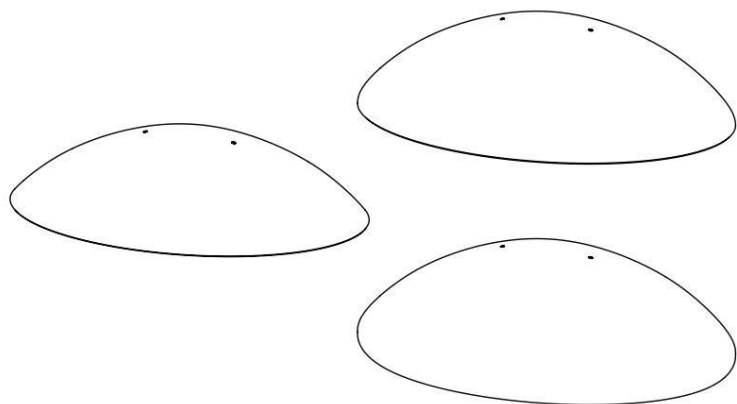

Sistema di posizionamento

Movimentazione con imbracature lunghe in poliestere.
Elemento autoportante. Appoggiato a terra.

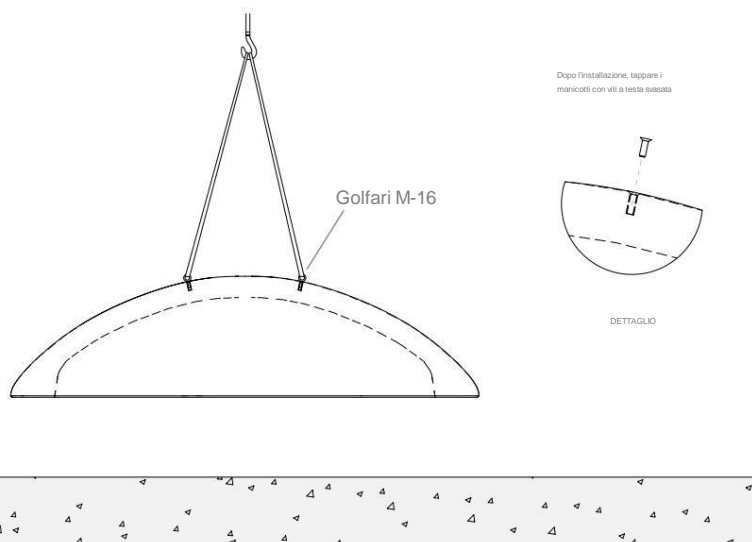

Island S1

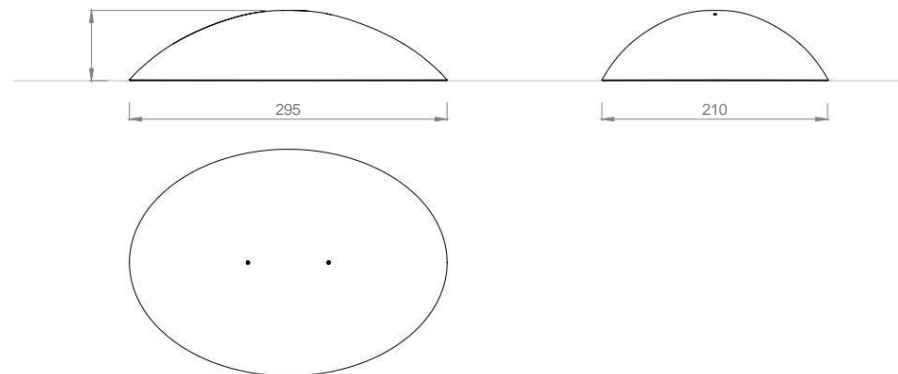

Island L1

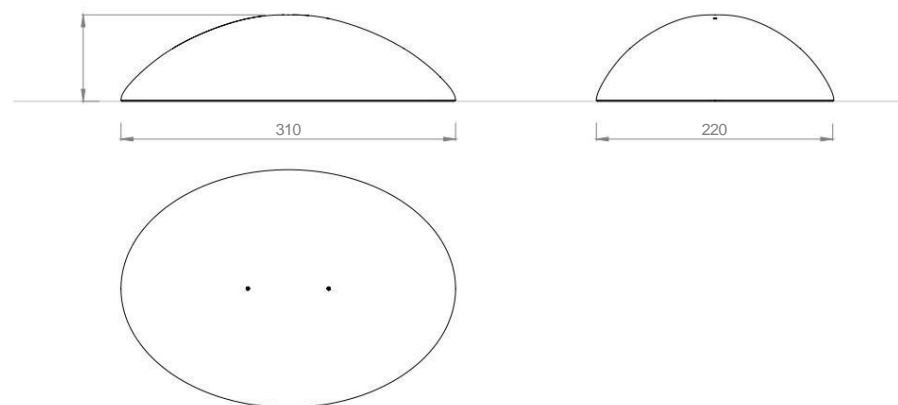

Island L2

